

# KPCI-1801HC KPCI-1802HC

# 333kHz, 12-Bit, High Channel Count Boards

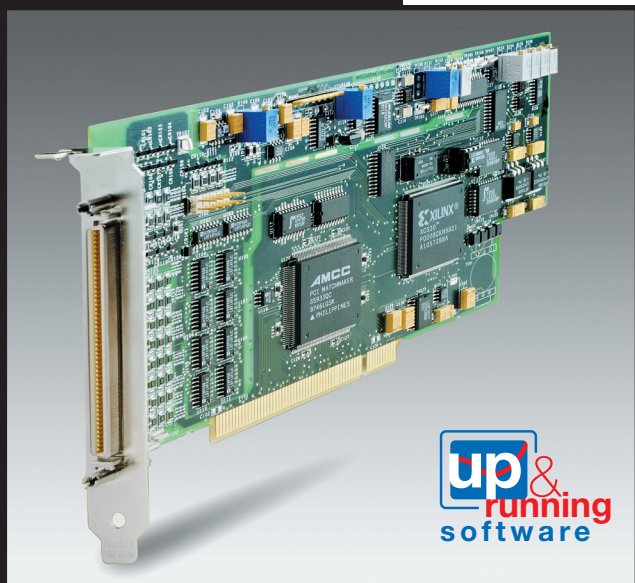

## Functional Description

The KPCI-1801HC/1802HC multifunction data acquisition boards combine high-performance with high-channel capacity. They make it simple to gather analog data, read and output digital signals, provide analog stimulus, and much more. Both boards provide 32 differential or 64 single-ended inputs and 2 analog outputs. The KPCI-1801HC offers software programmable high-gain inputs of 1, 5, 50, and 250, while the KPCI-1802HC features low-gain inputs of 1, 2, 4, and 8.

You can sample any single channel at any gain up to 333kSamples/s. Multiple channels can be sampled at aggregate rates up to 312.5kSamples/s.

These boards feature continuous, high-speed data acquisition. An onboard 2048-location FIFO buffer and 32-bit bus-mastering DMA ensure the continuous acquisition of large amounts of data. A 64-location channel gain queue allows high-speed acquisition with channels at different gains and in non-sequential order using DMA or interrupt-based data transfer modes. The KPCI-1801HC/1802HC support bus mastering, interrupt, or target mode data transfer methods.

The programmable burst mode capability allows you to acquire data from a series of channel scans at high speed with a programmed interval between scans. This mode emulates a simultaneous sample-and-hold function.

- 64 single-ended or 32 differential, 12-bit inputs
- Maximum sample rate up to 333kSamples/s
- High gain capability for thermocouples (KPCI-1801HC)
- 2K sample FIFO
- Burst mode
- Pre-, post-, and about-triggering
- 2 analog outputs
- 4 digital inputs, 8 digital outputs
- 32-bit DriverLINX drivers plus a suite of bundled software including ExceLINX, VisualSCOPE, TestPoint, and LabVIEW drivers

## Ordering Information

**KPCI-1801HC**  
PCI bus, high channel count, analog and digital I/O board – high gain

**KPCI-1802HC**  
PCI bus, high channel count, analog and digital I/O board – low gain

These boards feature flexible clocking, triggering, and gating modes. You can configure the boards to accept an external pacer clock input or use the onboard time base to provide a conversion rate from 4.32 samples/hour to 333kSamples/s. External hardware trigger and gate inputs allow precise control over when data is acquired, and flexible trigger modes allow you to acquire data in relationship to a specific event. An event that starts or stops acquisition can be either an internal or an external digital trigger. You can configure the boards for several triggering modes, including: pre-trigger, post-trigger and about-trigger.

- Pre-trigger mode allows acquisition to occur until an external trigger occurs.
- Post-trigger is the standard acquisition mode; acquisition begins after an internal or external trigger event and continues until an end condition occurs or the specified number of samples are collected.
- About-trigger mode allows acquisition to occur both before and after an external trigger.

The analog inputs are software-configurable for single-ended or differential inputs and bipolar or unipolar input ranges. The analog inputs are multiplexed into a high-speed 12-bit analog-to-digital converter. Two 12-bit analog outputs are provided with output voltage ranges of  $\pm 10.0V$ .

A total of 8 digital outputs and 4 digital inputs are available for control of the A/D and D/A converters. A strobe signal is provided for latching the digital output signals into external circuitry. +5V, -15V, and +15V are available at the connector for supplying power to external accessories or circuitry.

## ACCESSORIES AVAILABLE

C-16MB1	MB01 Backplane to STA-1800HC cable	CONN-1800HC	Connector/Cable Adapter Accessory
CAB-1800	KPCI-1801HC/1802HC to STA-1800HC 100-pin, 18" cable	MB-01**	16-Channel Direct-Connection Module Mounting Rack
CAB-1801	KPCI-1801HC/1802HC to STA-1800HC STP-100 100-pin, 36" cable	MB-02**	16-Channel Multiplexed Module Mounting Rack
CAB-1802	KPCI-1801HC/1802HC to STA-1800HC or STP-100 100-pin, 72" cable	MB-05**	8-Channel Direct-Connection Module Mounting Rack
CAB-1800/S*	KPCI-1801HC/1802HC to STA-1800HC or STP-100 100-pin, 18" shielded cable	STA-1800HC	Screw Terminal Accessory for CJC with Thermocouples
CAB-1801/S*	KPCI-1801HC/1802HC to STA-1800HC 100-pin, 36" shielded cable	STP-100	Screw Terminal Panel for 100-pin connectors
CAB-1802/S*	KPCI-1801HC/1802HC to STA-1800HC or STP-100 100-pin, 72" shielded cable	TESTPOINT	TestPoint Software Package

\*Required for CE emissions compliance

\*\*Signal conditioning modules for the MB-01, MB-02, and MB-05 can be found in the Signal Conditioning and Accessories section.

Combines high performance with high channel capacity

PCI/ISA/PCMCIA

1.888.KEITHLEY (U.S. only)

www.keithley.com

**KEITHLEY**

A GREATER MEASURE OF CONFIDENCE

# KPCI-1801HC KPCI-1802HC

# 333kHz, 12-Bit, High Channel Count Boards

## Specifications (KPCI-1801HC)

### ANALOG INPUTS

NUMBER OF CHANNELS: 32 differential or 64 single ended; software configurable.  
A/D FIFO BUFFER SIZE: 2048 samples.  
CHANNEL GAIN QUEUE LENGTH: 64 entries.  
A/D RESOLUTION: 12 bits.  
INPUT GAIN AND RANGE:

Gain	Range (Bipolar)	Range (Unipolar)
1	±5 V	0–5 V
5	±1 V	0–1 V
50	±100 mV	0–100 mV
250	±20 mV	0–20 mV

INPUT RANGE SELECTION: Software selectable via channel gain queue entry.  
INPUT OVERVOLTAGE: ±15V continuous, powered or unpowered.  
INPUT BIAS CURRENT: ±40nA maximum @25°C; ±60nA max. over operating range.  
INPUT IMPEDANCE: >100MΩ or greater in parallel with 90pF or less, all gains.  
SINGLE CHANNEL THROUGHPUT: 333kS/s.  
SCANNING THROUGHPUT (multiple channels scanned at the same gain):

Gain	Throughput (Bipolar)	Throughput (Unipolar)
1	312.5 kS/s	312.5 kS/s
5	312.5 kS/s	312.5 kS/s
50	312.5 kS/s	200 kS/s
250	75 kS/s	60 kS/s

LINEARITY: Integral: ±1 LSB max. Differential: ±1 LSB max.  
ERROR: ±0.02% reading ±1 LSB max. for gains < 250, @25°C typical.  
±0.03% reading ±1 LSB max. for gain = 250, @25°C typical.

### TEMPERATURE COEFFICIENTS:

Offset–Unipolar: ±10μV/°C ± (14μV/°C ÷ gain) typical.  
Offset–Bipolar: ±10μV/°C ± (12μV/°C ÷ gain) typical.  
Gain < 50: ±20ppm/°C typical.  
Gain = 50: ±30ppm/°C typical.  
Gain = 250: ±35ppm/°C typical.

### BIPOLAR INPUT ERROR 25°C ± 5°C

Range	Resolution (V)	%FSR	%rdg
±5 V	0.002441	0.051%	0.030%
±1 V	0.000488	0.055%	0.030%
±100 mV	0.0000488	0.100%	0.035%
±20 mV	0.00000976	0.300%	0.048%

### UNIPOLAR INPUT ERROR 25°C ± 5°C

Range	Resolution (V)	%FSR	%(rdg–[FSR/2])
0–5 V	0.001221	0.027%	0.030%
0–1 V	0.000244	0.031%	0.030%
0–100 mV	0.0000244	0.076%	0.035%
0–20 mV	0.00000488	0.276%	0.048%

Note: Accuracies and rms calculations are based on an average of 50 samples. Add noise to get maximum uncertainty of a single sample. FSR = Full Scale Range. rdg = Reading.

COMMON MODE REJECTION: Gain = 1: 74dB @ 60Hz. Gain = 5: 80dB @ 60Hz. Gain ≥ 50: 100dB @ 60Hz.

DATA TRANSFER MODES: DMA (PCI bus master), Interrupt (target-mode transfer), Polled (target-mode transfer).

### ANALOG OUTPUTS

NUMBER OF CHANNELS: 2.  
RESOLUTION: 12 bits.  
RANGE: ±10V  
ACCURACY: ±5mV typical unloaded; output impedance = 4Ω.  
OUTPUT CURRENT: ±5mA max.  
MAXIMUM CAPACITIVE LOAD: 100μF  
DATA TRANSFER MODES: DMA (PCI bus master), Interrupt (target-mode transfer), Polled (target-mode transfer).  
D/A FIFO BUFFER SIZE: 16 samples.

## Specifications (KPCI-1802HC)

### ANALOG INPUTS

NUMBER OF CHANNELS: 32 differential or 64 single ended; software configurable.  
A/D FIFO BUFFER SIZE: 2048 samples.  
CHANNEL GAIN QUEUE LENGTH: 64 entries.  
A/D RESOLUTION: 12 bits.  
INPUT GAIN AND RANGE:

Gain	Range (Bipolar)	Range (Unipolar)
1	±10 V	0–10 V
2	±5 V	0–5 V
4	±2.5 V	0–2.5 V
8	±1.25 V	0–1.25 V

INPUT RANGE SELECTION: Software selectable via channel gain queue entry.  
INPUT OVERVOLTAGE: ±15V continuous, powered or unpowered.  
INPUT BIAS CURRENT: ±40nA max. @25°C; ±60nA max. over operating range.  
INPUT IMPEDANCE: >100MΩ or greater in parallel with 90pF or less, all gains.  
SINGLE CHANNEL THROUGHPUT: 333kS/s.  
SCANNING THROUGHPUT (multiple channels scanned at the same gain):

Gain	Throughput (Bipolar)	Throughput (Unipolar)
1	312.5 kS/s	312.5 kS/s
2	312.5 kS/s	312.5 kS/s
4	312.5 kS/s	312.5 kS/s
8	312.5 kS/s	312.5 kS/s

LINEARITY: Integral: ±1 LSB max. Differential: ±1 LSB max.  
ERROR: ±0.02% reading ±1 LSB max. for gains < 250, @25°C typical.

### TEMPERATURE COEFFICIENTS:

Offset–Unipolar: ±10μV/°C ± (14μV/°C ÷ gain) typical.  
Offset–Bipolar: ±10μV/°C ± (12μV/°C ÷ gain) typical.  
Gain: ±20ppm/°C typical.

### BIPOLAR INPUT ERROR 25°C ± 5°C

Range	Resolution (V)	%FSR	%rdg
±10 V	0.004883	0.050%	0.030%
±5 V	0.002441	0.050%	0.030%
±2.5 V	0.001221	0.051%	0.030%
±1.25 V	0.00061	0.053%	0.030%

### UNIPOLAR INPUT ERROR 25°C ± 5°C

Range	Resolution (V)	%FSR	%(rdg–[FSR/2])
0–10 V	0.002441	0.026%	0.030%
0–5 V	0.001221	0.026%	0.030%
0–2.5 V	0.00061	0.027%	0.030%
0–1.25 V	0.000305	0.029%	0.030%

Note: Accuracies and rms calculations are based on an average of 50 samples. Add noise to get maximum uncertainty of a single sample. FSR = Full Scale Range. rdg = Reading.

COMMON MODE REJECTION: Gain = 1; 74dB DC–60Hz.

(typical): Gain = 2, 4; 80dB DC–60Hz.  
Gain = 8; 86dB DC–60Hz.

DATA TRANSFER MODES: DMA (PCI bus master), Interrupt (target-mode transfer), Polled (target-mode transfer).

### ANALOG OUTPUTS

NUMBER OF CHANNELS: 2.  
RESOLUTION: 12 bits.  
RANGE: ±10V  
ACCURACY: ±5mV typical into high impedance; output impedance = 4Ω.  
OUTPUT CURRENT: ±5mA max.  
MAXIMUM CAPACITIVE LOAD: 100μF  
DATA TRANSFER MODES: DMA (PCI bus master), Interrupt (target-mode transfer), Polled (target-mode transfer).  
D/A FIFO BUFFER SIZE: 16 samples.

1.888.KEITHLEY (U.S. only)

www.keithley.com

KEITHLEY

A GREATER MEASURE OF CONFIDENCE

# KPCI-1801HC KPCI-1802HC

# 333kHz, 12-Bit, High Channel Count Boards

## Configuration Guide

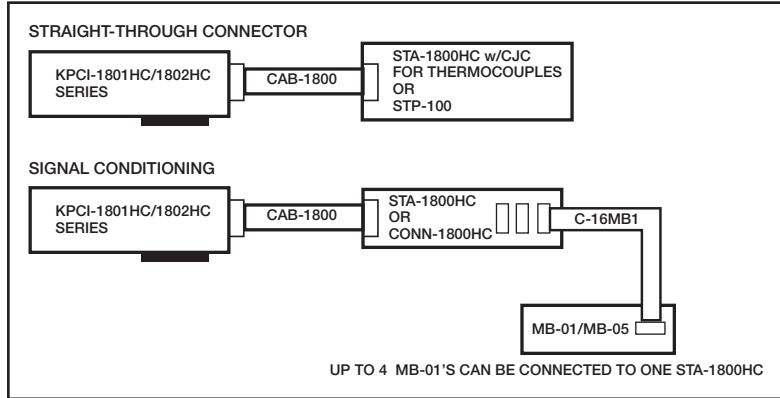

## ENVIRONMENT

**TEMPERATURE, OPERATING:** 0°C to 50°C.

**TEMPERATURE, NONOPERATING:** -20°C to 70°C.

**HUMIDITY:** 0 to 95% Relative (non-condensing), operating or nonoperating.

**EMC:** Conforms to European Union directive 89/336/EEC.

**SAFETY:** Conforms to European Union directive 73/23/EEC (meets EN 61010-1/IEC 1010).

**DIMENSIONS:** 203mm long × 108mm wide × 19mm deep (8 in × 4.25 in × 0.75 in).

## Connector Pin Assignments

The analog input, analog output, digital input, and digital output connections are made with a 100-pin D-type connector at the rear of the computer.

	Bank A Pin	Bank B Pin	
	1	1	AGND
	2	2	CH00 HI
CH16 LO / CH48 HI	3	3	CH00 LO / CH32 HI
CH17 HI	4	4	CH01 HI
CH17 LO / CH49 HI	5	5	CH01 LO / CH33 HI
CH18 HI	6	6	CH02 HI
CH18 LO / CH50 HI	7	7	CH02 LO / CH34 HI
CH19 HI	8	8	CH03 HI
CH19 LO / CH51 HI	9	9	CH03 LO / CH35 HI
CH20 HI	10	10	CH04 HI
CH20 LO / CH52 HI	11	11	CH04 LO / CH36 HI
CH21 HI	12	12	CH05 HI
CH21 LO / CH53 HI	13	13	CH05 LO / CH37 HI
CH22 HI	14	14	CH06 HI
CH22 LO / CH54 HI	15	15	CH06 LO / CH38 HI
CH23 HI	16	16	CH07 HI
CH23 LO / CH55 HI	17	17	CH07 LO / CH39 HI
AGND	18	18	AGND
CH24 HI	19	19	CH08 HI
CH24 LO / CH56 HI	20	20	CH08 LO / CH40 HI
CH25 HI	21	21	CH09 HI
CH25 LO / CH57 HI	22	22	CH09 LO / CH41 HI
CH26 HI	23	23	CH10 HI
CH26 LO / CH58 HI	24	24	CH10 LO / CH42 HI
CH27 HI	25	25	CH11 HI
CH27 LO / CH59 HI	26	26	CH10 LO / CH43 HI
CH28 HI	27	27	CH12 HI
CH28 LO / CH60 HI	28	28	CH12 LO / CH44 HI
CH29 HI	29	29	CH13 HI
CH29 LO / CH61 HI	30	30	CH13 LO / CH45 HI
CH30 HI	31	31	CH14 HI
CH30 LO / CH62 HI	32	32	CH14 LO / CH46 HI
CH31 HI	33	33	CH15 HI
CH31 LO / CH63 HI	34	34	CH15 LO / CH47 HI
AGND	35	35	AGND
DAC1 OUT	36	36	DAC0 OUT
-15V	37	37	+15V
DGND	38	38	DGND
NC	39	39	DIO/XPCLK
SSHO	40	40	DII/TGIN
TGOUT	41	41	DI2
DOSTB	42	42	DI3
DO4	43	43	DO0
DO5	44	44	DO1
DO6	45	45	DO2
DO7	46	46	DO3
+5V	47	47	+5V
+5V	48	48	+5V
DGND	49	49	DGND
DGND	50	50	DGND

**KPCI-1801HC/1802HC**

1.888.KEITHLEY (U.S. only)

www.keithley.com

**KEITHLEY**

A GREATER MEASURE OF CONFIDENCE